

COPYRIGHT NOTICE:

David S. Richeson: Euler's Gem

is published by Princeton University Press and copyrighted, © 2009, by Princeton University Press. All rights reserved. No part of this book may be reproduced in any form by any electronic or mechanical means (including photocopying, recording, or information storage and retrieval) without permission in writing from the publisher, except for reading and browsing via the World Wide Web. Users are not permitted to mount this file on any network servers.

Follow links for Class Use and other Permissions. For more information send email to: permissions@press.princeton.edu

APPENDIX A

BUILD YOUR OWN

POLYHEDRA AND SURFACES

A great way to learn about polyhedra and topological surfaces is to build them by hand. The pages that follow contain templates for making the five Platonic solids, the torus, the cylinder, the Möbius band, the Klein bottle, and the projective plane.

Here is some advice for making paper models:

1. Photocopy the templates from the book. Enlarge the copy to get larger models.
2. Copy the templates on heavy paper or card stock. Alternately, copy onto an adhesive sheet and stick this onto a piece of cardboard.
3. Carefully cut out the templates using a sharp knife and a straightedge.
4. Score the folds with a dull knife to guarantee nice, sharp creases.
5. Use the tabs if you want to glue the model together. Cut the tabs off if you intend to tape the model together.

Tetrahedron

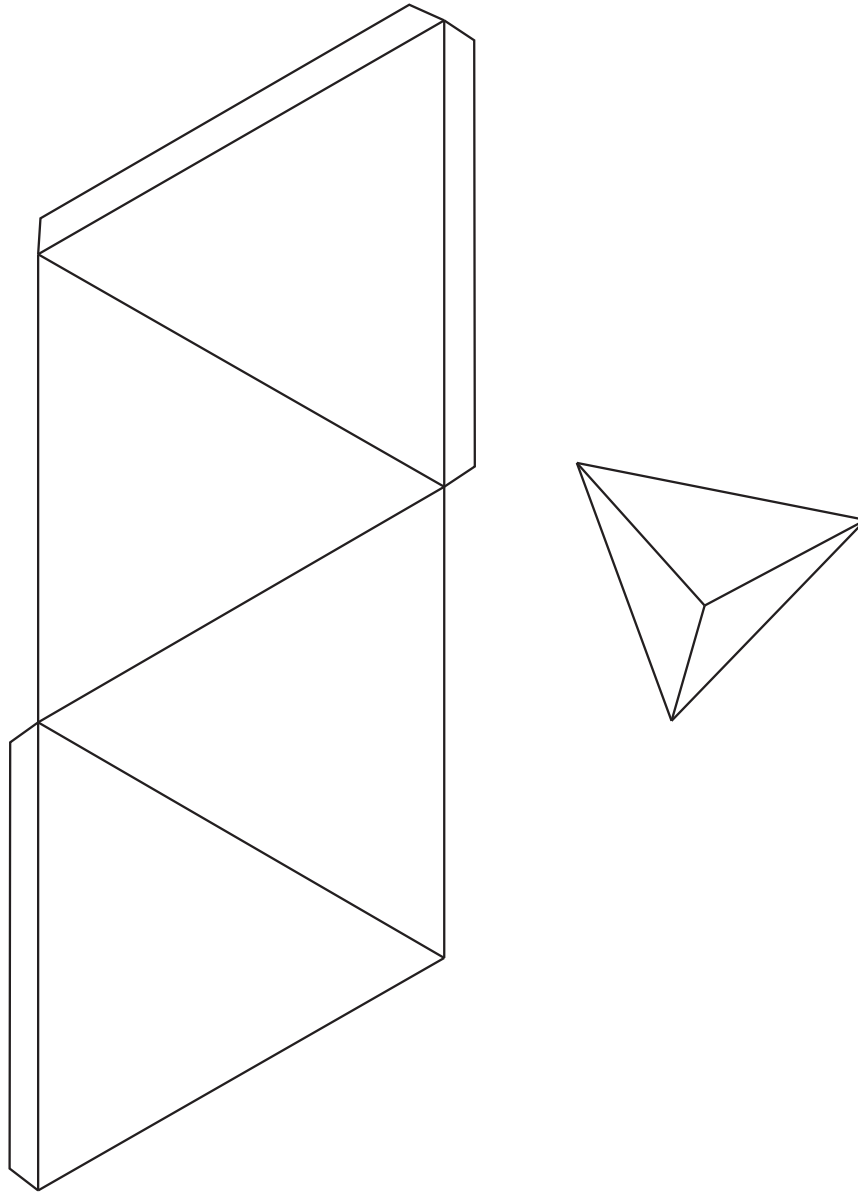

Cube

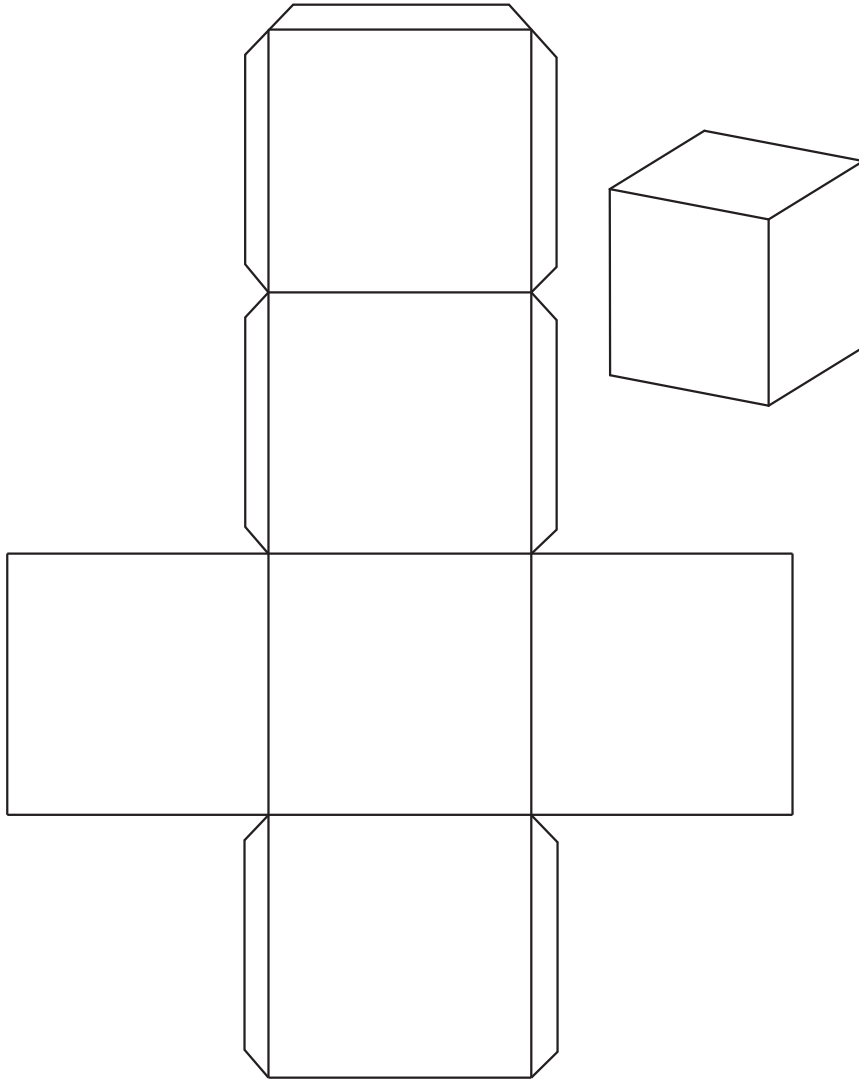

Octahedron

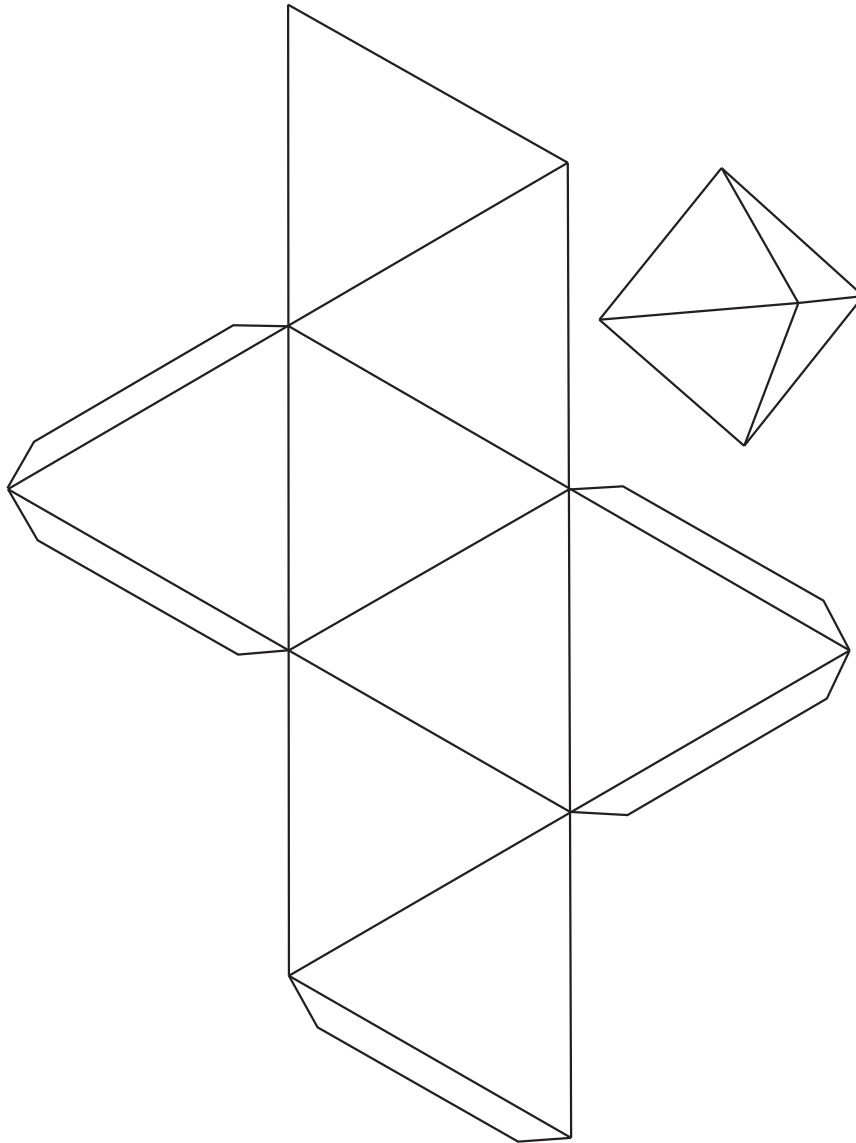

Icosahedron

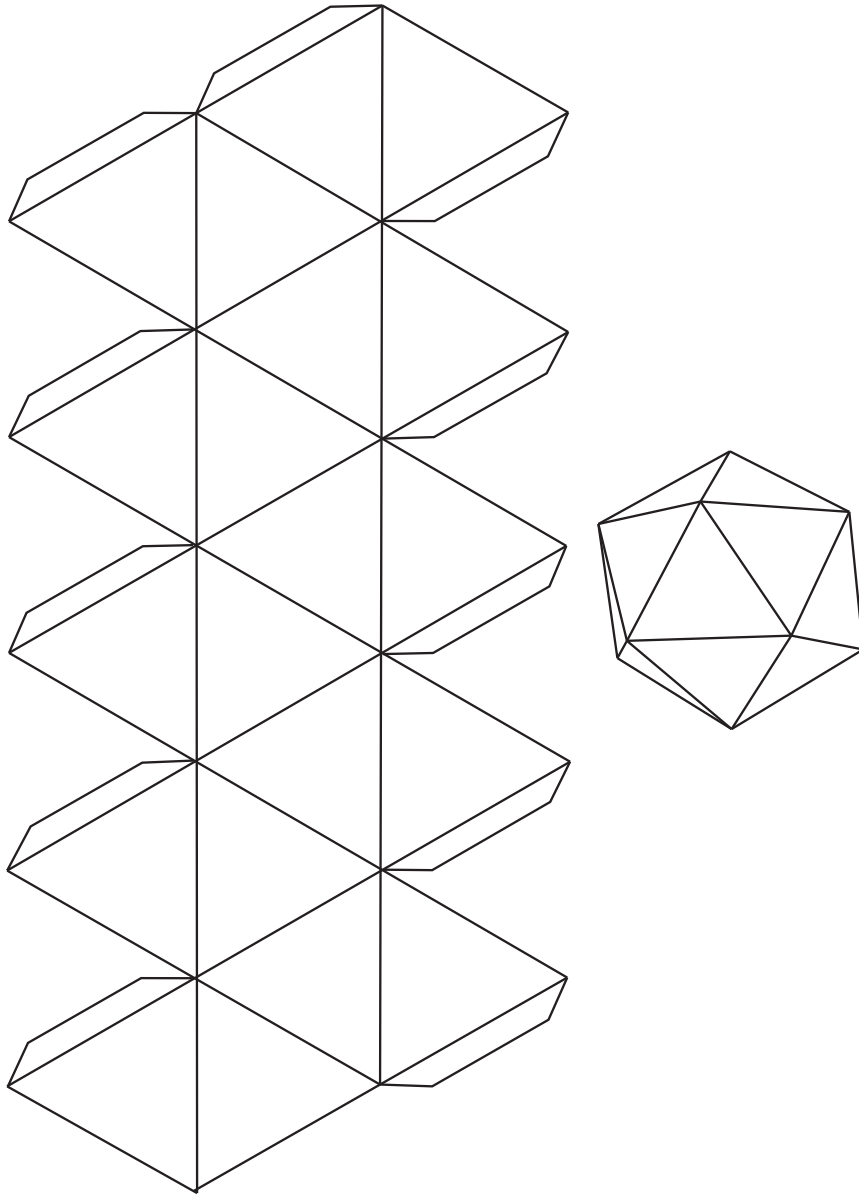

Dodecahedron

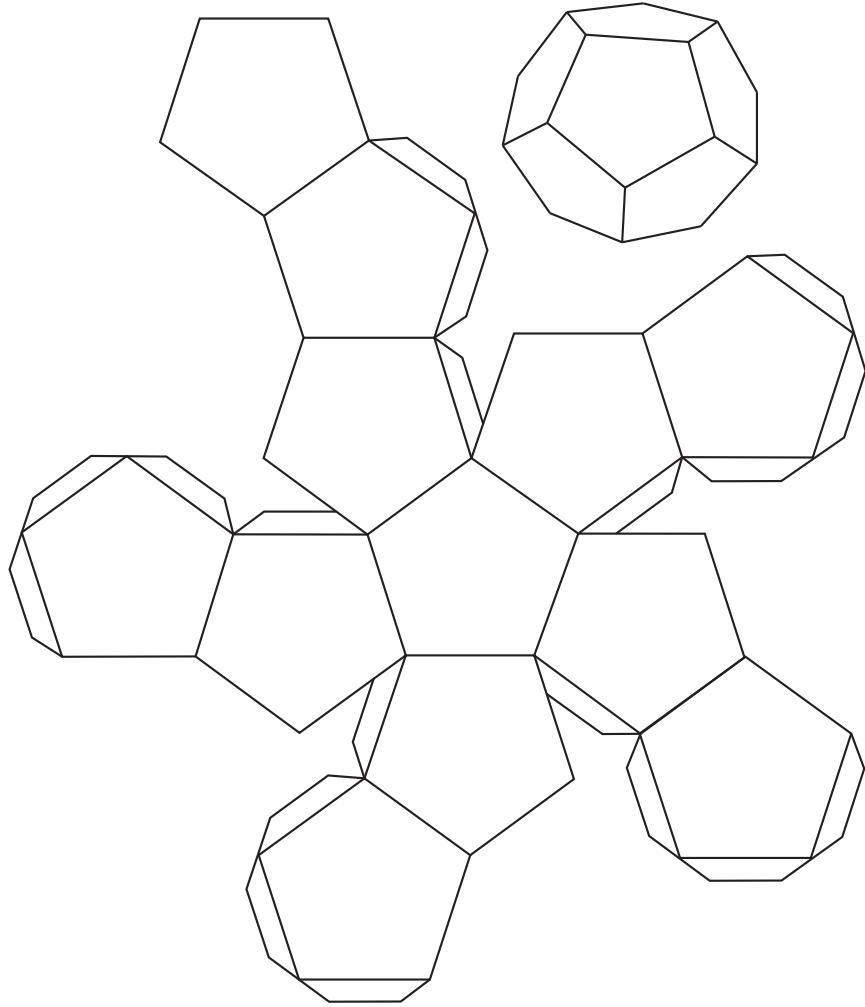

Torus

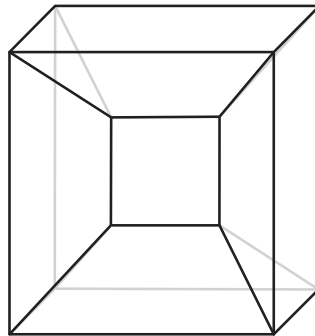
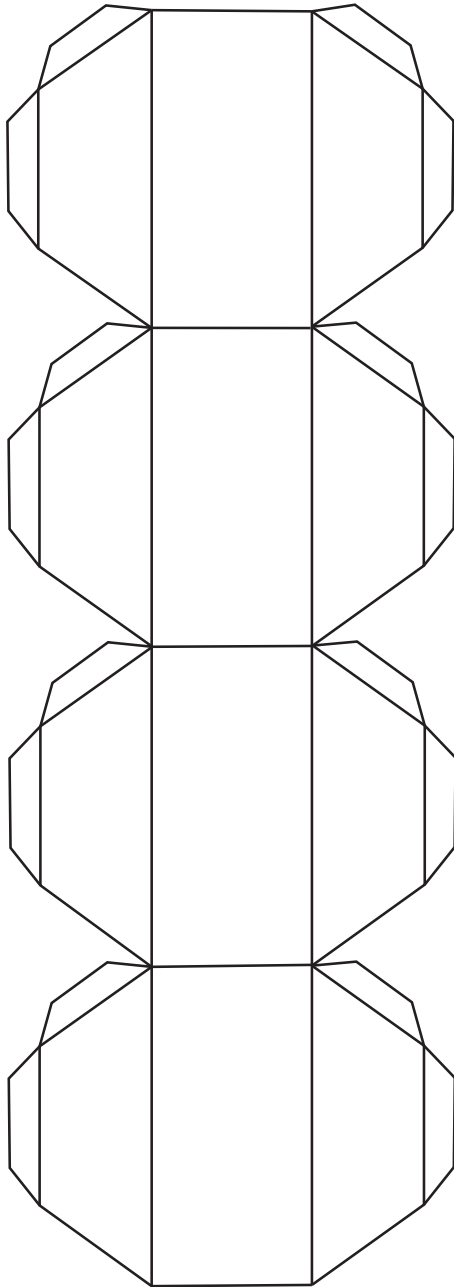

Möbius bands (or cylinders)

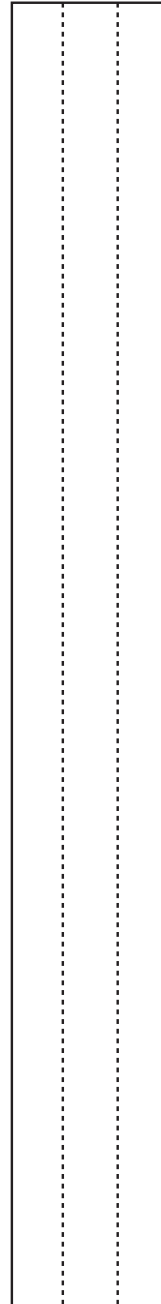
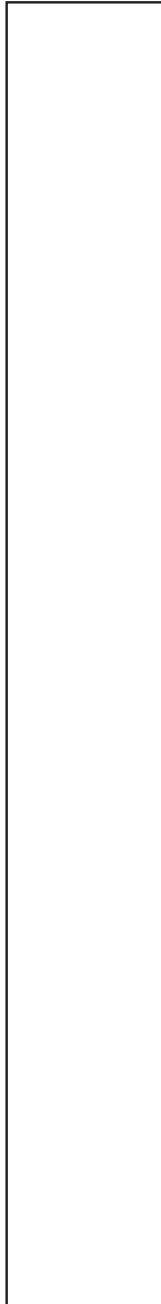

Klein bottle

